

ADAPTIVE FUZZY CONTROLLER IMPLEMENTED ON THERMAL PROCESS

M. ABD EL-GELIEL

Automation Laboratory, Mannheim University,
68131 Mannheim, Germany
elgeliel@rumms.uni-mannheim.de

Abstract. Fuzzy controller is one of the succeed controller used in the process control in case of model uncertainties. But it may be difficult to fuzzy controller to articulate the accumulated knowledge to encompass all circumstance. Hence, it is essential to provide a tuning capability. There are many parameters in fuzzy controller can be adapted, scale factor tuning of normalized fuzzy controller is one of the adaptation parameter. Two adaptation methods are implemented in this work on an experimental thermal process, which simulate heating process in liquefied petroleum gases (LPG) recovery process in one of petrochemical industries: Gradient decent (GD) adaptation method; supervisory fuzzy controller. A comparison between the two methods is discussed.

Key words: LPG, DCS, Supervisory controller, Normalized Fuzzy Controller

1 INTRODUCTION

Since many industrial processes are of a complex nature, it is difficult to develop a closed loop control model for this high level process. Also the human operator is often required to provide on line adjustment, which make the process performance greatly dependent on the experience of the individual operator.

It would be extremely useful if some kind of systematic methodology can be developed for the process control model that is suited to kind of industrial process.

There are some variables in continuous DCS (distributed control system) suffer from many unexpected disturbance during operation (noise, parameter variation, model uncertainties, etc.) so the human supervision (adjustment) is necessary and frequently. If the operator has a little experience the system may be damage or operated at lower efficiency [1,4]. One of these systems is the liquefied petroleum gases (LPG) recovery process in one of petrochemical industries at Egypt. LPG recovery process is a multi-input/output process, PI controller is the main controller used to control the process variable. Process is exposed to unexpected conditions and the controller fail to maintain the process variable in satisfied conditions and retune the controller is necessary.

Fuzzy controller is one of the succeed controller used in the process control in case of model uncertainties. But it may be difficult to fuzzy controller to articulate the accumulated knowledge to encompass all circumstance. Hence, it is essential to provide a tuning capability [2,3,14,16,17]. There are many parameters in fuzzy controller can be adapted, scale factor tuning of normalized fuzzy controller is one of the adaptation parameter. Two adaptation methods are implemented in this work on an experimental thermal process, which simulate heating process in LPG recovery process: Gradient decent (GD) adaptation method; supervisory fuzzy controller.

The heating process of LPG unit construction and operation will be described. Adaptive controller is suggested here to adapt normalized fuzzy controller, mainly output/input scale factor. The algorithm is tested on an experimental model to the heating process in LPG unit. A compares ion between

scale factors adjust and classical adaptation method are done. The suggested control algorithm consists of two controllers: process variable controller (normalized fuzzy controller); a adaptive controller to adjust the scale of the normalized controller. Normalized fuzzy controller is explained in [3,4,10,11] and the previous methods of scale factor selection are discusses in [3-7]. The priorities of input or output scale factors selection are introduced in [8].

In the second section of this paper, we present the the heating process in LPG recovery process and the control problem, an experimental model to simulate the control problem in the LPG recovery process is introduced and the analogy between the actual process and experimental model is explained. In the third section, the GD [4,9,12]adaptation method algorithm is implemented on the experimental process. In the last section the fuzzy supervisory adaptive implemented and compared with GD adaptive controller.

2 LPG RECOVERY PROCESS AND THERMAL PROCES

LPG is a light saturated paraffinic hydrocarbon derived from the refinery process crude petroleum oil stabilization and natural gas processing plants. They consist mainly of propane (C₃H₈) and butane (C₄H₁₀) or combination of the two and some other hydrocarbons. They are mainly liquefied under pressure for transportation and storage.

The LPG recovery process is to separate the main components of LPG, C₃H₈, C₄H₁₀ and the other hydrocarbons. The separation takes place at a certain heating temperature.

One of the LPG recovery process, in ANRPC Petroleum Company in Egypt, starts by Deethanizer (Ethan separation C₂H₆) process followed by Depropanizer and Debutanizer process.

The schematic Diagram of the Deethanizer recovery process is shown in Fig.1. Treated LPG is feed to the upper of the separation tower and the outlets of the tower are Ethan and treated LPG.

The Deethanizer Recovery process requires a certain conditions of temperature, level and pressure. Each process variable (Temperature, Level and Pressure) in the recovery process is controlled by an individual control loop in the DCS. PI controller is the main controller for almost control loop.

The temperature of Ethan produced is controlled through deethanizer reboiler by changing the steam flow rate to the reboiler. The Ethan temperature must be maintained at 420 °c all the time. The heating of LPG is performed using steam and variation in the steam flow rate lead to the variation of the process temperature. Hence process temperature is controlled by adjusting the inlet steam and outlet condensed water flow rate to and from the reboiler unit as in Fig.1. Where the steam conditions (pressure and temperature) vary during operation, the temperature controller cannot maintain the temperature around the allowable range 420°C ± 2%. For this reason a human supervision is necessary all the time in order to limits the system variation.

The loop tuning is done based on the human experience with some trial and error. In order to avoid the instability and less accuracy of process performance, the human supervisory play an important roll in process adjustment and operations.

This type of process is a continuous and complex process and the process identification has a lot of approximations. The conventional controller cannot handle all situation of the process, which mainly depends on the system model. An adaptive system is necessary to adapt the controller parameters. Moreover, the controller used in such process must be fast and simple because of the huge number of controlled variables and to reduce the computational burden.

Artificial Intelligent control technique needs to well known by the process operation (experience) in order to construct/learn the controller of the process variables. But all the process situations may take place during operations inconsiderable during controller construction and start up so, the adaptation method also necessary in case of using AI controller [2]. Due to all reasons discussed, an adaptive controller with some experience of the process and without actual process model is preferred to adjust the variable response in most of the process situations and reduce the effort on the human supervision.

An adaptive fuzzy controller is suggested to control and adapt most of single input/output in any DCS system loop. This algorithm is constructed and tested on an experimental thermal process model, simulated to the temperature loop control of the deethanizer LPG recovery process.

2.1 EXPERIMENTAL PROCESS

the Reboilar unit in LPG recovery process is simulated by thermal process as in Fig. 2.

The thermal process is a single input-single output system (SISO). The apparatus consists of a versatile controller, an electrically heated model process and condition unit. The model is an electrically heated, aluminum process block surrounded by a water jacket, into which is inserted a platinum resistance thermometer. The model is designed so that it is, in effect, a speed up version on an industrial process with time constants shortened, to make the experiments of suitable duration for university engineering laboratories.

The control problem investigated is that of maintaining the process temperature under variation of heat losses (by changing the cooling water flow rate).

The actual temperature is measured using resistor thermometer. The temperature signal is suitably amplified to drive 200mv/°c for each one degree change.

The control of the power to the process heater is achieved using the thyristor circuit operating in burst firing mode. The average power to the heater is controlled from 0 to 100% via controlling the root mean square value of the heater voltage from 0 to 220v. Which equivalent to -10 to +10 control signal.

The thermal model is a small simulation of the Deethanizer reboilarunit. the analogy between the simulated unit and actual one is summarized in the following points:

- 1-The variation of the steam conditions in the actual process is equivalent to variation of cooling water flow rate in the process model.
- 2-The control signal in the actual process varies the steam flow rate to change LPG temperature also the control signal in the thermal model changes the average power to the electric heater.

3-The controlled variable in the actual process is the outlet Ethan temperature but in the model is the water temperature.

2.2 EXPERIMENTAL PROCESS IDENTIFICATION

To obtain the mathematical model of the process, i.e. to identify the process parameters, the process is looked as a black box, an input step is applied (20 °C), to the process to obtain the open loop time response, as shown in Fig. 3. From the time response, the transfer function of the open loop system can be approximated in the form of a second order transfer function:

$$G(s) = \frac{1.165}{(25s + 1)(250s + 1)} \quad (1)$$

The identified model is approximated as a linear model, but exactly the closed loop system is nonlinear due to the limitation in the control signal (± 10). Using the method of PID tuning [14,13] gives the following tuning parameters:

$$K_p = 60, K_i = 80, \text{ and } K_d = 20.$$

These parameters gave a good response in this case but the main draw back that, if the system exposed to a random disturbance (variable flow rate), the response oscillates as shown in Fig. 4 and PID controller parameters must be retuned. Retuning the parameters in the system like LPG is very critical and need a high experience. So another approach must be introduced to avoid this problem.

3 IMPLEMENTATION OF ADAPTIVE FUZZY CONTROLLER ON EXPERIMENT CASE STUDY

3.1 NORMALIZED FUZZY CONTROLLER

To over come the problem of PID parameter variation, a normalized Fuzzy controller with adjustable scale factors is suggested. In our experimental case study, the fuzzy controller designed has the following parameters:

- Membership functions of the input/output signals have the same universe of discourse equal to 1
- The number of membership functions for each variable is 5 triangle membership functions denoted as NB (negative big), NS (negative small), Z (zero), PS (positive small) and PB (positive big) as shown in Fig. 5.
- Fuzzy allocation matrix (FAM) or Rule base as in Table1.
- Fuzzy inference system is mandani.
- Fuzzy inference methods are “min” for AND, “max” for OR, “min” for fuzzy implication, “max” for fuzzy aggregation (composition), and “centroid” for Defuzzification.

Adjusting the gains according to the simulation results, the system responses for differnt input/output gains are shown in Fig. 6. From the analysis of the above responses, we can conclude that:

- decreasing input scale factors increase the response offset.
- Increasing output scale factor fasting the response of the system but may case some oscillation.

So the selection must compromise between input and output scale factors.

In the following section we try to adapt the output scale factor with constant input scale factor at 10 error scale, and 15 rate of error scale based on manual tuning result. There are two method tested to adapt the output scale factors, GD (Gradient Decent) adaptation method and supervisor fuzzy.

3.2 OUTPUT SCALE FACTOR ADAPTATION USING GD ADAPTATION METHOD

The adaptive variable here is the output scale factor gain (demormalization factor). Therefore, the GD method seeks to decrease the value of the quadratic objective function based on the instantaneous error

$$e(k): J(k) = 1/2 e^2(k). \quad (2)$$

The error here is a plant output error e_y

$$e_y(k) = y_m(k) - y(k). \quad (3)$$

The performance index will be:

$$J(k) = \frac{1}{2} (y_m(k) - y(k))^2 \quad (4)$$

Where:

$y_m(k)$ is the reference modeled output.
 $y(k)$ is the actual output.

The overall block diagram of the adaptation system using GD method shown in Fig. 7, we take the reference model output as a step.

the parameter set, $\theta(k)$, of the fuzzy scale factor is changed via the following iterative adaptation rule:

$$\theta(k+1) = \theta(k) + \Delta\theta(k) = \theta(k) - \alpha \partial J(k) / \partial \theta(k) \quad (5)$$

Where:

α is the adaptation parameter, which controls how much the parameter is altered at each iteration.

Θ is the scale factor.

according to GD techniques [4,9,12] the derivative term will be:

$$\partial J(k) / \partial \theta(k) = e \partial e(k) / \partial \theta(k) \quad (6)$$

then

$$\theta(k+1) = \theta(k) + \Delta\theta(k) = \theta(k) - \alpha e \partial e(k) / \partial \theta(k) \quad (7)$$

differentiates equation (2):

$$\partial e(k) / \partial \theta(k) = - \partial y(k) / \partial \theta(k) \quad (8)$$

where y_m does not affect by Θ

According to the adaptation equation (7) we can deduce that response will depend on the following parameters :

- adaptation factor α
- initial value of scale facto gains.
- fuzzy system inference.

By fixing the fuzzy inference system (normalized fuzzy described above). then the main parameters that affect on the response will be α and Θ_0 .

Fig. 8 shows the response of the experimental system when $\Theta_0=1$ and $\alpha=0.5$. Fig. 9 shows the responses for different values of α (0.1, 0.3, 0.5 and 1).

the selection of initial gain and adaptation factor is chosen by trial and error. There is no specific method to determine the optimal value but there is a guide values. For instance, adaptation factor range $0 < \alpha < 2$ [4] other wise the response oscillate. Also the initial value should to be $0 < \Theta_0 < \text{maximum universe of discourse of the control membership function}$.

It has been noted that, the responses obtained using GD methods is slow compared to the previous responses.

3.3 FUZZY SUPERVISOR ADAPTATION

In this method we try to design a supervisor fuzzy controller to change the scale factors on line. design of the supervisor can be constructed by two methods:

- learning method[1,2,12,17]
- Experience of the system and main requirements must be achieved.

In thisworks, the supervisor controller is built according to the accumulative knowledge of the previous tuning methods.

The supervisor fuzzy controller has the following parameters:

- the universe of discourse of input and output is selected according to the maximum allowable range and that is depend on the process requirements (5.5)
- The number of membership functions for input variables is 3 triangle membership functions denoted as N (negative), Z (zero), and P (positive). For output variable is 2 membership functions denoted as L (low) and H (high) as shown in Fig. 10 (5.6)
- Fuzzy allocation matrix (FAM) or Rule base as in Table 2.
- Fuzzy inference system is mandani.
- Fuzzy inference methods are “min” for AND, “max” for OR, “min” for fuzzy implication, “max” for fuzzy aggregation (composition), and “centroid” for Defuzzification.

The overall block diagram of the system with supervisor controller is shown in Fig. 11. Firstly, we supervise the output gain only as in GD method to compare between them. reference model is a unity gain. Fig. 12 shows the system response using supervisory fuzzy controller. Fig. 13 compare between the best responses using GD with supervisor fuzzy response. The two responses are almost similar. The response of supervisor fuzzy is relatively faster.

Tuning both input and output scale factors using supervisor controller, the supervisor fuzzy will be multi-input multi-output fuzzy controller without coupling between the variables, i.e. the same supervisor algorithm is applied to each output individually with different universe of discourses. The scale factor of the error signal is limited by the maximum allowable error according to equation (9).

$$U_r = 1/e_{\max}. \quad (9)$$

Where U_r :universe of discourse of error membership functions.

e_{\max} : maximum allowable error

Fig. 14 compares between output scale supervision and output/input supervision. It is noted that, input/output supervision reduces the ripple which can be happen.

All the previous results are taken with considering that the reference response is step. In practice, there is no physical system can be changed from initial value to final value in now time. So, the required performance is transferred to a reference model and the system should be forced to follow the required response (overshoot, rise time, etc.). The desired specification of the system should to be: overshoot $\leq 20\%$; rise time $\leq 150\text{sec}$; based on the experience of the process. the desired response which achieves the desired specification is described by equation (10).

$$y_d(t) = A * [1 - 1.59 e^{-0.488t} \sin(0.3929t + 38.83 * \pi / 180)] \quad (10)$$

where A: step required.

Fig. 15 compares between the two responses at different flow rate (50% and 80%) and reference model response. This indicates a good responses and robustness controller.

4 conclusion

Fuzzy controller is one of the succeed controller used in the process control in case of model uncertainties. But it my be difficult to fuzzy controller to articulate the accumulated knowledge to encompass all circumstance. Hence, it is essential to provide a tuning capability. There are many parameters in fuzzy controller can be adapted, scale factor tuning of normalized fuzzy controller is one of the adaptation

parameter. Two adaptation methods are implemented in this work on an experimental thermal process, which simulate heating process in LPG recovery process: Gradient decent (GD) adaptation method; supervisory fuzzy controller.

If we analysis the responses of the thermal models for different adaptation methods we can conclude that:

. GD methods give a relatively slow response and depend on the initial values of the algorithm parameters. Another drawback of GD method that, some times the adaptation equation is very hard to implement. For instance if we used the GD method to adapt the input scale factor, the equation is not easy to obtain because it depend on the type of fuzzy system used and FIS tools (membership functions type, fuzzy imprecation method, fuzzy controller type,..., etc).

. The suggested approach (Fuzzy supervision) is easy to built and give a good response. The mathematical tools are very simple. The supervisory algorithm does not dependent on the main fuzzy controller and its parameters (normalized fuzzy and FIS). The generalization of the suggested algorithm

Table 1 FAM OF NONRMALIZED FUZZY CONTROLLER

6 References

[1] Han-Xiong Li and Shouping Guan, "Hybrid Intelligent Control Strategy", IEEE Control System Magazine, pp 36-48, June 2001
 [2] "The Control Handbook", IEEE press, CRC 1996, P.P. 994-1017
 [3] Leonid Reznik, "Fuzzy Controllers", Newness, 1997.
 [4] Kovacic Z., Cupec R. and Bogdan S., "A Servo Positioning by using Model Reference Adaptive Fuzzy controller", Proc., IFAC 2001.
 [5] Plam R. "Scaling of Fuzzy Controllers Using the Cross-correction", IEEE Transaction on Fuzzy Systems, vol. 3 no1, pp 116-130, 1995.

[6] Yager R. R. and Filer D. P. Essentials of Fuzzy Modeling and Control, John Wiley, 1994.
 [7] Renznik L. and Stoica A., "Some Tricks in Fuzzy Controller design", In: Proceedings of Australia and new Zealand Conference on Intelligent information systems, ANZIIS-93, IEEE, Perth, Western Australia, pp. 60-64, 1993
 [8] J. M. Mendel, "Fuzzy Logic Systems for Engineering: A tutorial", Proc. IEEE, vol. 83, pp. 345-377, 1995.
 [9] Marco Russo Lakhumi C. Join, Fuzzy Learning and Applications, CRC Press, 2001
 [10] M. A. Elgeliel, "Model reference based supervisory fuzzy logic controller for process control", ISTAD MIC 2003 Conference, Austria, Feb. 10-13, 2003.
 [11] M. A. El-Geliel, "Supervisory Fuzzy Logic Controller used for Process Loop Control in DCS System", CCA03 Conference, Istanbul, Turkey, June 23/25, 2003.
 [12] L. X. Wang, Adaptive Fuzzy System & Control design & Stability Analysis, Prentice-Hall, 1994.
 [13] M. A. El-Geliel, "Computer Based control of Thermal Process Using Fuzzy Logic and PID controller", M.Sc. Thesis, Arab Academy for Science and Technology, June 2000
 [14] Kal Johan Astroum and Bjorn Wittenmark, "Adaptive control", Addison-weslly, 1995
 [15] L. H. Tsoukvlav and R. E. Uhring, "Fuzzy and Neural Approaches in Engineering", John Wiley Sons, inc., 1997
 [16] C. J. Harris, C. G. Moore, and M. Brown, Intelligent Control Aspects of Fuzzy Logic and Neural Nets, World Scientific, 1993.
 [17] Junhang Nie and Derek. A. Linkens, Fuzzy-Neural Control Principle, algorithms and application, Prentice-Hall Europe, 1995.

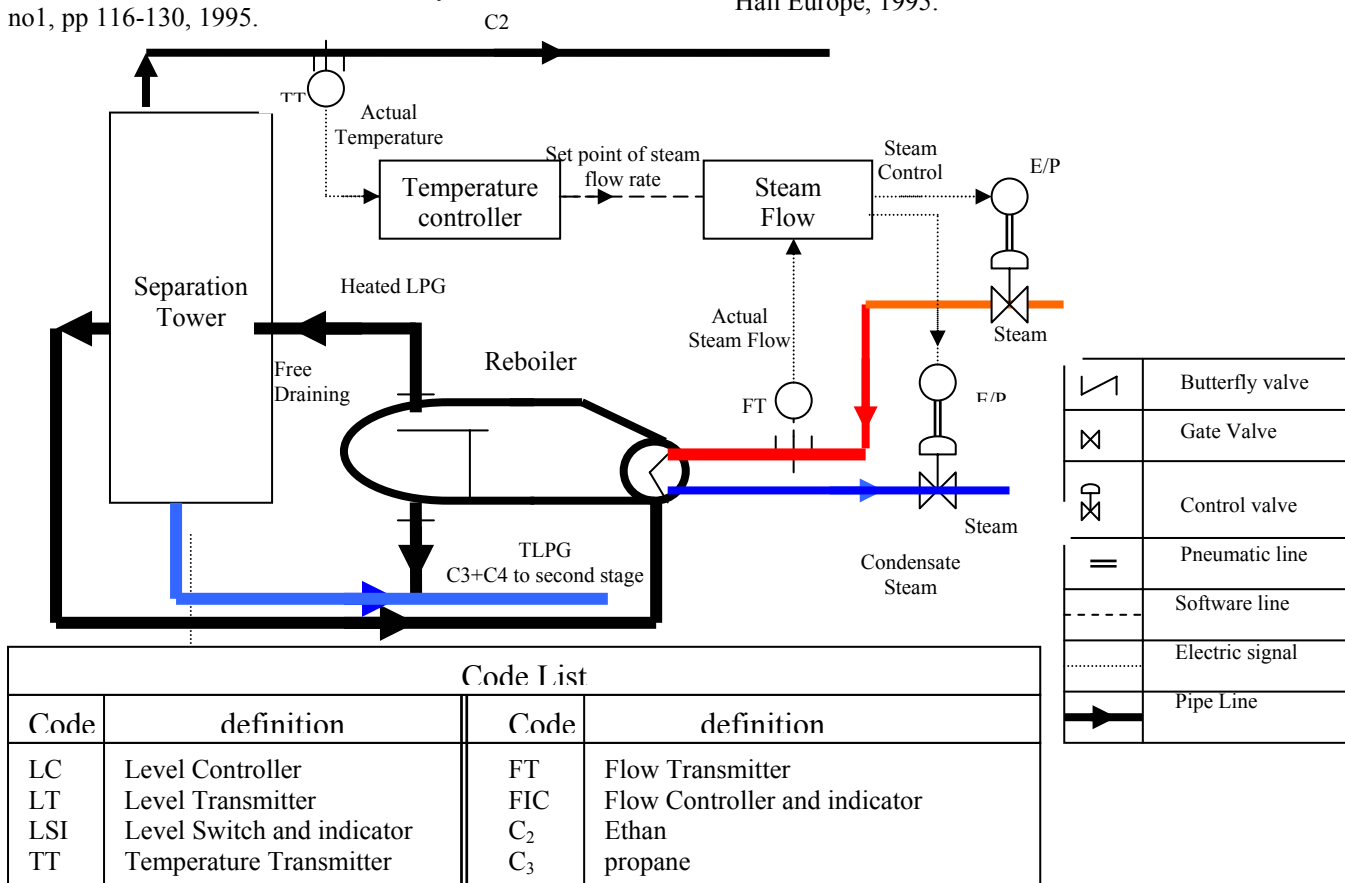

Fig. 5.1 Schematic diagram of Deethanizer LPG Recovery process

Table 1 FAM OF NORMALIZED FUZZY CONTROLLER

$e \backslash \Delta e$	NB	NM	Z	PM	PB
NB	PB	PB	PM	Z	Z
NM	PM	PB	PM	Z	Z
Z	PM	PM	Z	NM	NM
PM	Z	Z	NM	NB	NB
PB	Z	NM	NB	NB	NB

Table 2 FAM OF SUPERVISORY FUZZY CONTROLLER

$e \backslash \Delta e$	N	Z	P
N	H	H	L
Z	L	L	H
P	L	H	H

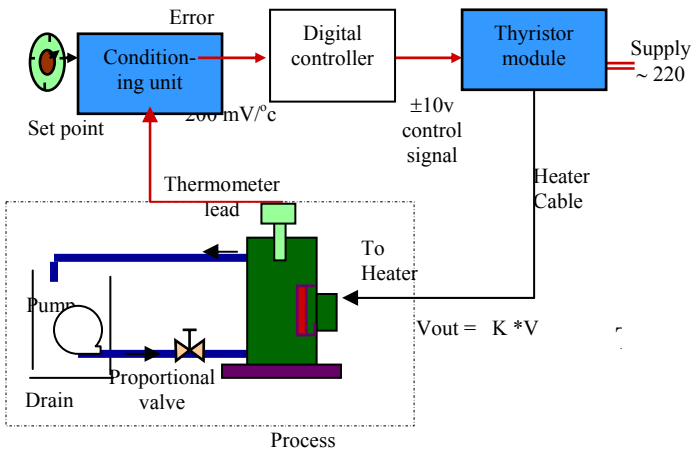

Fig. 2 Schematic diagram of thermal process

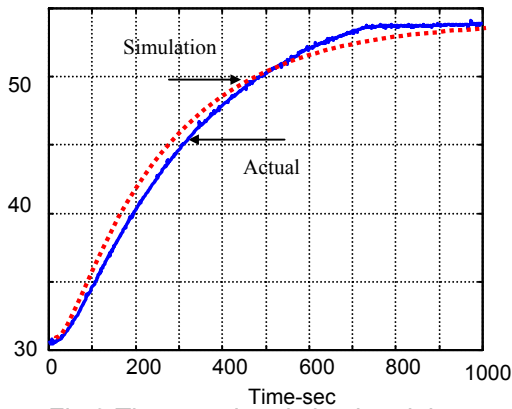

Fig 3 The actual and simulated time responses of the temperature process.

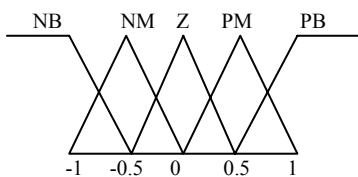

Fig. 5 Normalized membership function of inputs and output variables

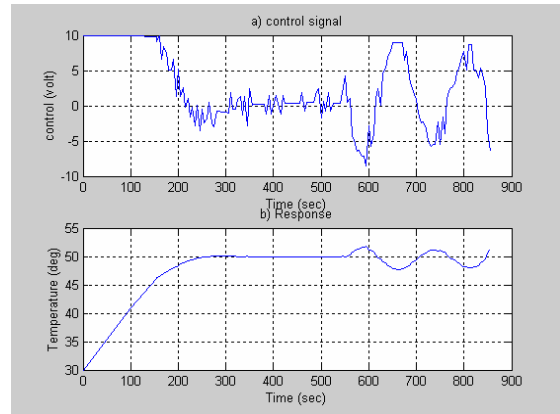

Fig. 4 Tuned PID response with disturbance effect

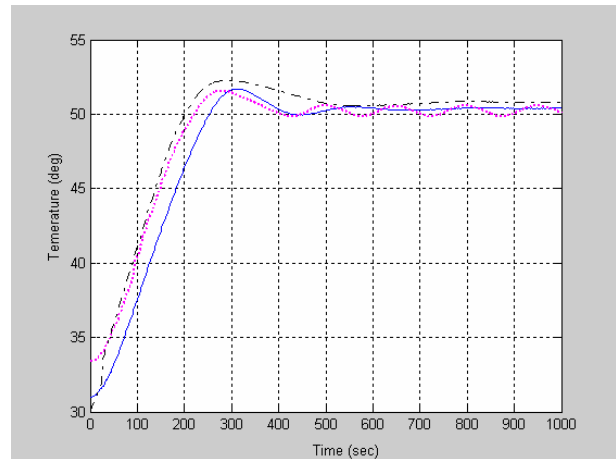

Fig 6 Actual responses for different input output gains

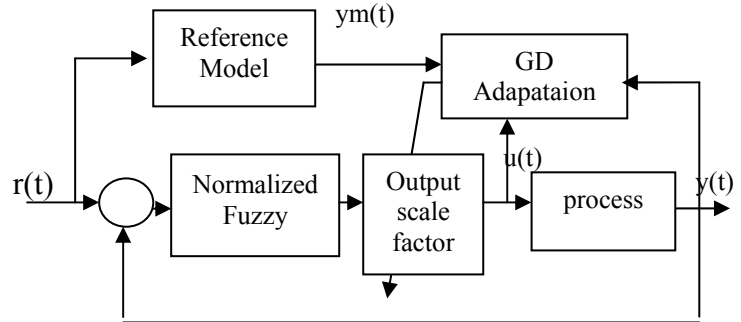

Fig. 7 GD adaptation system

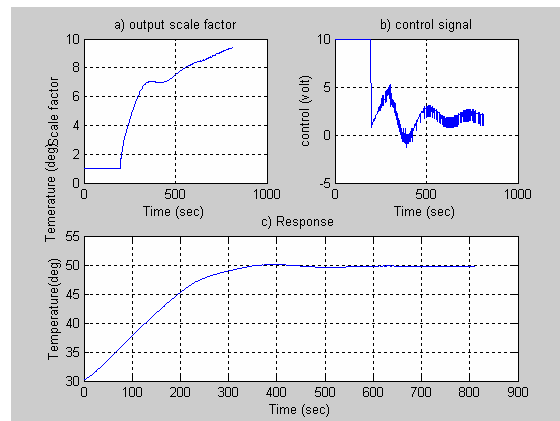

Fig. 8 Actual response using GD method in case of $\alpha=0.5$ and initial gain = 1

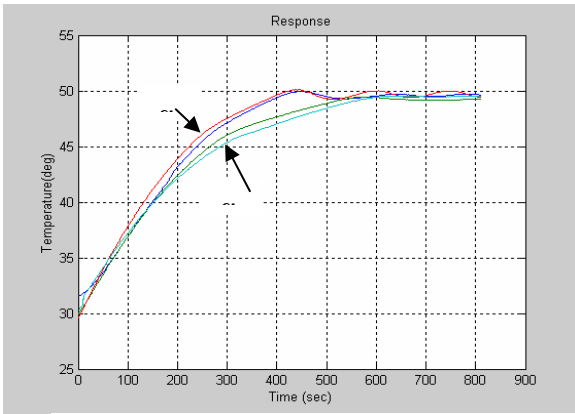

Fig. 9 Different responses for different values of α at gain = 10

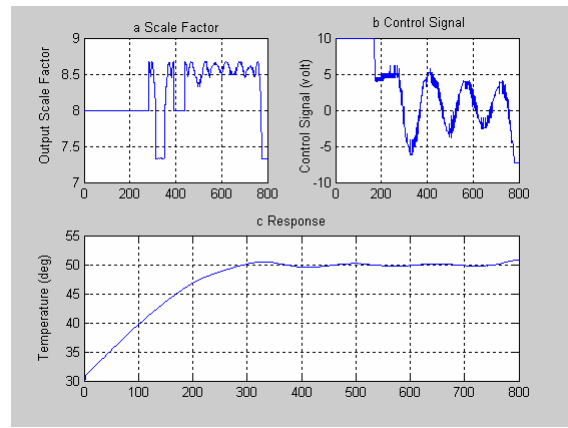

Fig. 13 supervisor fuzzy control to adapt the output scale factor

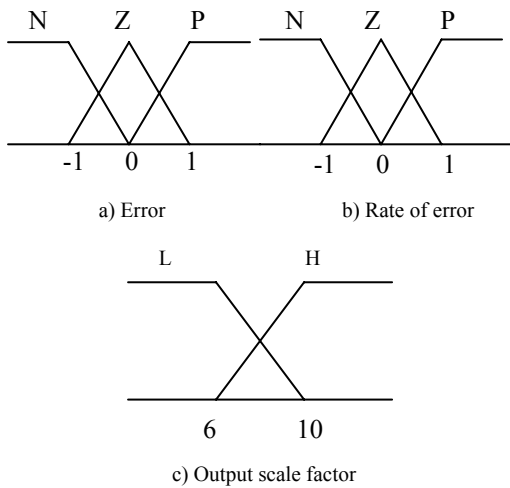

Fig. 10 Membership Function of inputs and output of supervisory fuzzy controller

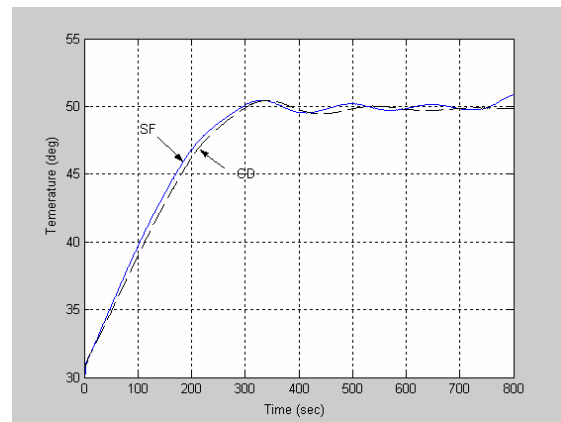

Fig. 14 Response of GD adaptation and Supervisor fuzzy

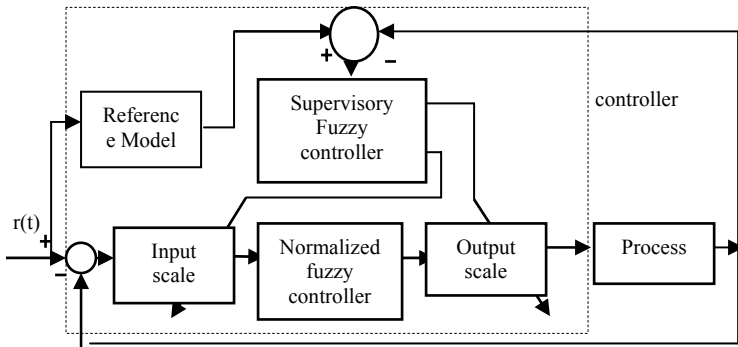

Fig. 11 Over-all Block of the supervisory fuzzy controller.

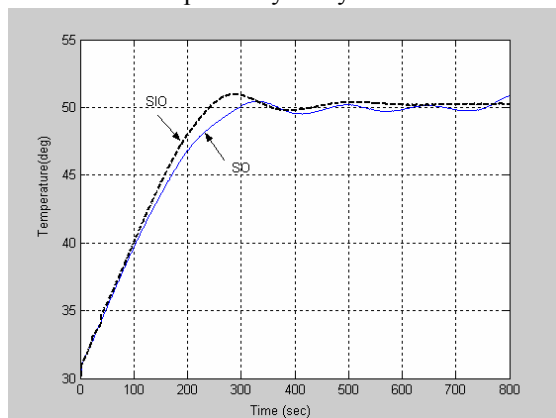

Fig. 12 System responses for single and multi-output supervisor

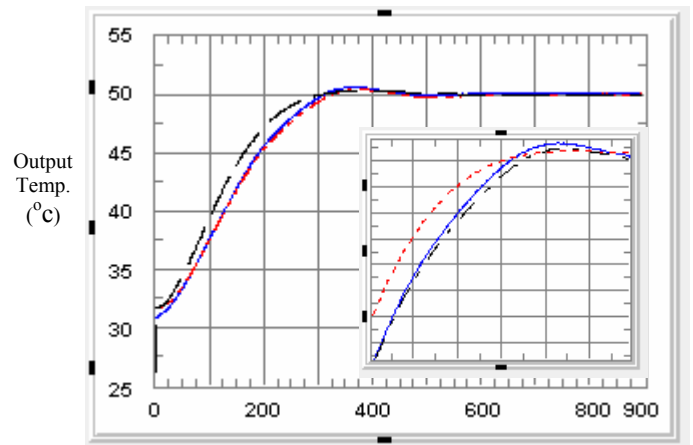

Fig. 15 Model reference supervisory fuzzy controller response for different cooling water flow rate

- Flow rate 50%
- - - Flowrate 80%
- - - Reference model output